

Project Database
Spanish Railways Technological Platform

Monographic RETOS-COLABORACIÓN
Spanish National R&D and Innovation Programme

Rail Projects Analysis
2014, 2015, 2016 Calls

FOREWORD

The **Spanish Ministry of Economy, Industry and Competitiveness** has the capacity, in the framework of the National Programme for Research and Innovation oriented to the Challenges of Society, to finance and stimulate, through the launch of public aid competitive calls, scientific research, technological investigation and development, and innovation directed to answer the challenges of society.

RETOS-COLABORACIÓN is one of the tools used to achieve this objective. This instrument represents an opportunity for companies and R&D agents, for the execution of innovative projects in cooperation and with results close to the market that mobilize private investment, generate employment and improve the country's technological balance.

The Spanish Railways Technological Platform (PTFE) has gathered key information from the awarded RETOS-COLABORACIÓN projects, as provided on a voluntary basis by the project participants, with respect to rail results on the **2014, 2015 and 2016 calls**. It is a live document that will be enlarged with each new call and with further project factsheets that may be submitted. For further information do not hesitate to contact PTFE Technical Secretariat.

RETOS-COLABORACIÓN Programme

- Financed by the Spanish Ministry of Economy, Industry and Competitiveness
- Three calls: 2014, 2015, 2016
- Open to a broad range of societal challenges and thematic
- Analysis of awarded **RAIL** projects through an open call to PTFE members to submit information on the RETOS-COLABORACIÓN projects in which they are involved
- Information on 17 projects has been received

Project classification per thematic area

Thematic Area	Projects
Platform, superstructure, track and instalations	PREDIVIA (2014) SOLBAN (2015) ICEBURNER (2015) ROBOTRACK (2015) RECOVER (2015) SINATU (2016) HERMES (2016) CIFIL (2016)
Rolling Stock	BEA (2015) SENSEROD (2016) RENERSEG (2015) AXIS (2016) PYRKAST (2016)
Policies, planning, economy, energy and sustainability	OPTICON (2015)
Exploitation, operation and rail system security and safety	ALIS (2015) CARE (2016) SIGNAL (2016)

*Data analysed:
 17 RAIL PROJECTS
 Retos-colaboración 2014, 2015, 2016*

RETOS-COLABORACIÓN - Participants

Company	# Projects as leader*
VÍAS Y CONSTRUCCIONES	4
COMSA	3
CAF	2
FGC	2

Company	# Projects*
FGC	6
VÍAS Y CONSTRUCCIONES	4
COMSA	3
CEIT	3
CAF	2
CTM	2
LEITAT	2
TELICE	2
UPC	2
UPM	2
UPV	2

Projects leadership



Projects participation



Rail entities with higher participation*

*Data analysed:
 17 RAIL PROJECTS

Retos-colaboración 2014, 2015, 2016

2014 CALL

1 rail project factsheet received

– PREDIVIA

PREDIVIA. Development of a detection and monitoring system of mechanical failures based on acoustic emission for the predictive maintenance of track diversions

DESCRIPTION

The overall objective of the project is to develop technologies able to detect, to predict the evolution and to make a diagnosis of incipient cracks in initial states situated in critical elements of the railway infrastructure such as switch tongue of track diversions. This will make possible to predict the component fracture once the crack is detected.

RESULTS

The continuous monitoring of such elements will result in a substantial increase in infrastructure security as well as a reduction in costs of operation and maintenance; maximizing the availability of the infrastructure, increasing its effective life and minimizing the impact of repair operations.

KEY FIGURES

Call: Retos-Colaboración 2014. Ministerio de Economía Industria y Competitividad (RTC-2014-2960-4)
Duration: 2014 - 2017
Total budget: 872.917€

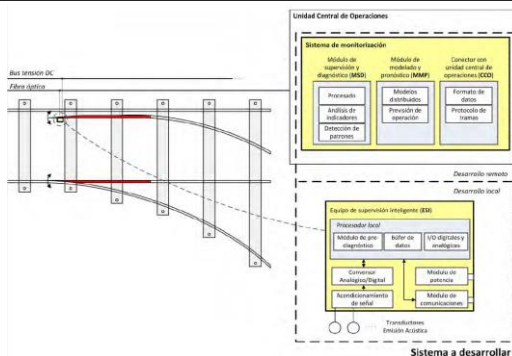

CONSORTIUM

Ferrocarrils de la Generalitat de Catalunya
Fundació CTM Centre Tecnològic INGIMEC



2015 CALL

7 rail project factsheets received

- **ALIS**
- **ICEBURNER**
- **OPTICON**
- **RECOVER**
- **RENERSEG**
- **ROBOTRACK**
- **SOLBAN**

ALIS. Modeling based on Intelligent Algorithms for the integration of electrification, safety and energy efficiency in railway systems

DESCRIPTION

This Project has been proposed by Inabensa, Universidad Politécnica de Madrid and Universidad de Málaga. It focuses on the development of a simulation tool which includes characteristics, that are currently non-existent in the market. This development has emerged from the internal need that was detected by the Engineering Railway Department (Inabensa). This result has achieved for first time the integration of electrification systems design, installations and traveller safety and energy efficiency which focus on design as well as the exploitation.

RESULTS

The end result of the project will be a simulation tool divided into modules. The concepts included are related to concepts of optimal location of substations, behavior of pantographs within the interaction with catenary, development of modules associated with safety in the vicinity of railway systems, both for workers, travelers and passers-by in general, and affections of the rail system. In addition, we will not lose sight of the analysis of the energy re-use of regenerative braking with its corresponding systems of storage, use of renewable energy and efficient driving.

KEY FIGURES

Call: Retos Colaboración - 2015

Duration: 2015 - 2017

Total budget: 777.981,62 €



CONSORTIUM

*Inabensa Abengoa
 Universidad Politécnica de Madrid
 Universidad de Málaga*



ICEBURNER. HIGH PERFORMANCE IN EFFICIENCY, AVAILABILITY AND VERSATILITY RAILPOINT HEATING SYSTEMS

DESCRIPTION: The objective of the ICEBURNER project is the design and development of a heating system for points by induced currents that exceeds the performance of the products currently available in the market.

RESULTS: ICEBURNER represents a great leap in the performance of point heaters, improving in the following areas:

Improved availability through the following points:

- Modular power electronics with two parallel solutions that allow fault tolerance
- Possibility of connection of external batteries that allows to maintain the functions at least 4h in a reduced working regime
- Configuration of hot spots on rail or slab with possibility of redundancy for fault tolerance

Improving efficiency

- Use of induction heaters with rail or plate heating by induced currents, which allows to go from an efficiency of 20% to a greater than 80%
- Power regulation that allows to adapt the power consumed to the external environmental conditions

Improved versatility

- Self-diagnosis function of the installation
- Communications with checkpoint for monitoring and remote control
- Design of inductors with multiple configurations for the same power electronics
- Single inductor installation-uninstall solution to facilitate substructure maintenance

KEY FIGURES

Call :Retos-Colaboración 2015. Ministerio de Economía y Competitividad (RTC-2015-3659-4)

Duration: 2015-2018

Total Budget: 770.257,04

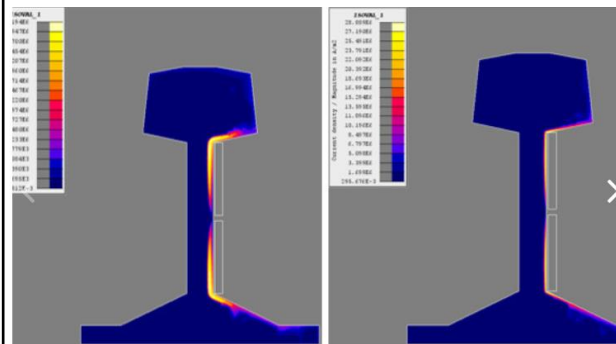

CONSORTIUM

Vias y Construcciones



OPTICON. Tool to aid decision-making in the optimization of the electric consumption of railway systems based on the flow of vehicles and infrastructure characteristics

DESCRIPTION

The aim of this project is to develop a decision making support tool for railway and infrastructure operators to optimize the electric consumption of the system. To address the objective is intended to develop a software capable to simulate a complete rail network in terms of energy consumption and able to give response to answers like: Which electricity supply contract suits better?, Which way of driving reduces the consumption while maintains the quality of service?, What time of return does it have to introduce an ATP or a converter change?

RESULTS

The developed platform will include:

- Model of the power supply network, including all components of the electrical infrastructure such as traction substations, catenary or converters.
- Model of consumption of the traction system, which will include the dynamics of the train as well as the auxiliary consumptions.

The result of this project will be a tool capable to simulate in a reasonable time the whole rail network in terms of energy consumption.

KEY FIGURES

Call: Retos-Colaboración 2015. Ministerio de Economía Industria y Competitividad (RTC-2015-4320-4)

Duration: 2015 - 2018

Total budget: 889.904,88€

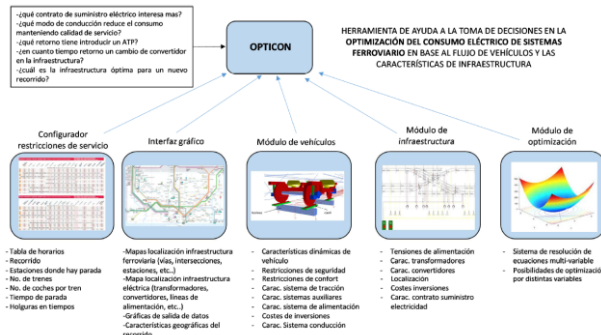

CONSORTIUM

Ferrocarrils de la Generalitat de Catalunya
Vias y Construcciones CEIT



RECOVER. Comprehensive sustainable anti-pollution treatment for the creation of green railway corridors

DESCRIPTION

The project seeks to create green railway corridors by means of systems for removing contaminants associated with the operation of the infrastructure, especially in relation to ballast, allowing an environmental improvement of the track itself and its surrounding area. To do this, it intends to design several systems for heavy metals and hydrocarbons pollutants capture and removal through different technologies:

- Sol-gel ballast coating composed of silicon oxide and complexing functional groups capable of absorbing heavy metals, and photocatalytic titanium oxide capable of degrading hydrocarbons
- Ballast modified by fixing ionically printed polymers based on polyurethanes
- Soil microbial population phytoremediation and bioaugmented processes

RESULTS

It aims to achieve: Design of systems to capture and eliminate heavy metals and hydrocarbons in the ballast and soil adjacent to railway tracks and generation of pollution-free zones associated with the circulation of trains.

KEY FIGURES

Call: 2015 (RTC-2015-4043-4)

Duration: 2015-2018

Total budget: 857.110,60 Euros

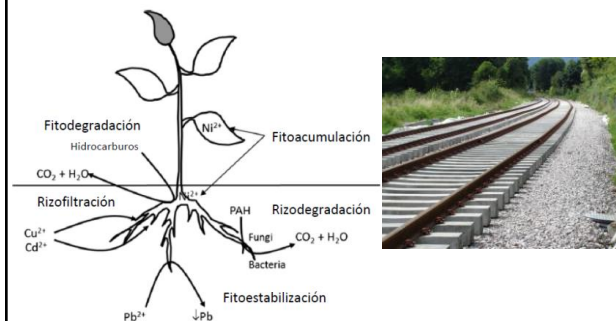

CONSORTIUM

COMSA, S.A.U., Fundación
CETIM, LEITAT

RENERSEG. New running gear for improving energy efficiency and safety in passenger trains.

DESCRIPTION

This new running gear system involves the development, on the one hand, of a new suspension which will allow to increase the comfort and safety level when travelling under certain degraded conditions; and on the other hand, the development of a new energy storage system.

RESULTS

The development of this new running gear will make possible to meet the requirements of safety, dynamic behavior and comfort without reducing speed under certain degraded conditions, while improving the energy efficiency of the vehicle.

KEY FIGURES

Call: Retos-Colaboración 2015. Ministerio de Economía y Competitividad (RTC-2015-3977-4)

Duration: 2015-2017

Total budget: 708.974,05€

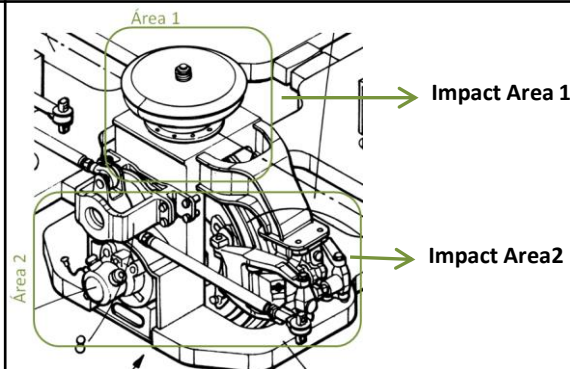

Diagram of the areas where the project will impact

CONSORTIUM

PATENTES TALGO, S.L.U. (Leader)
 Universidad Politécnica de Madrid



ROBOTRACK. Robotization of commissioning systems for a new concept of lightweight track

DESCRIPTION

The overall objective of the Robotrack project is the development of a new economic and sustainable ballastless track, specially designed to establish an innovative fully automated installation process using a new robotic system.

RESULTS

From a global perspective, the project proposes innovations in design, materials and processes which allows the product to be much more competitive with respect to the ballastless tracks that currently exist in the market.

KEY FIGURES

Call: Retos-Colaboración 2015. Ministerio de Economía Industria y Competitividad (RTC-2015-3692-4)

Duration: 2015 - 2018

Total budget: 1.061.907€

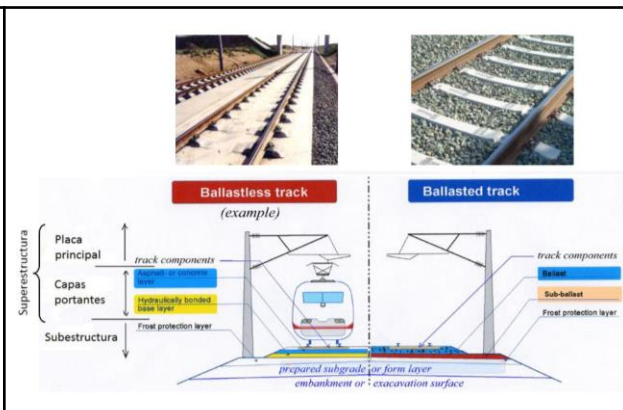

CONSORTIUM

Ferrocarrils de la Generalitat de Catalunya
 Centro de Estudios de Materiales y control de Obra Vías y Construcciones
 Centro Tecnológico Acamm
 Universitat Politècnica de València



SOLBAN. Development of an advanced welding procedure of new carbide free bainitic steels for rail

DESCRIPTION

The objective of SOLBAN is the design and development of a novel welding process, specially designed for high performance rail qualities and the instrumentation of the rail using state-of-the-art sensors for track monitoring and maintenance.

RESULTS

An experimental quality rail has been developed and the welding parameters for crackling and aluminothermic welding have been defined. A robotic welding head has been designed to automate the process and achieve a low level of defects.

In addition, sensors with wireless communication systems for specific maintenance have been developed and installed on the ArcelorMittal rail network.

KEY FIGURES

Call: Retos-Colaboración 2014. Ministerio de Economía y Competitividad (RTC-2014-2313-4)

Duration: 3 years

Total budget: 886.905,05 €

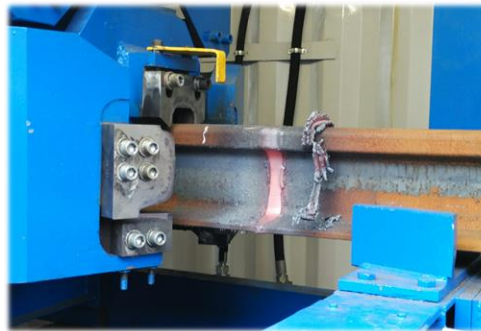

CONSORTIUM

ARCELORMITTAL; ITMA; UNIOVI



2016 CALL

9 rail project factsheets received

- **AXIS**
- **BEA**
- **CARE**
- **CIFIL**
- **HERMES**
- **PYRKAST**
- **SENSEROD**
- **SIGNAL**
- **SINATU**



AXIS. High reliability advanced technologies to maximize the life, safety and availability of railway vehicles in service

DESCRIPTION

Development of damage tolerance methodologies and inspection technologies to monitor the structural integrity of railway axles in service that will improve the safety of these components and reduce vehicle LCC costs increasing their availability.

RESULTADOS

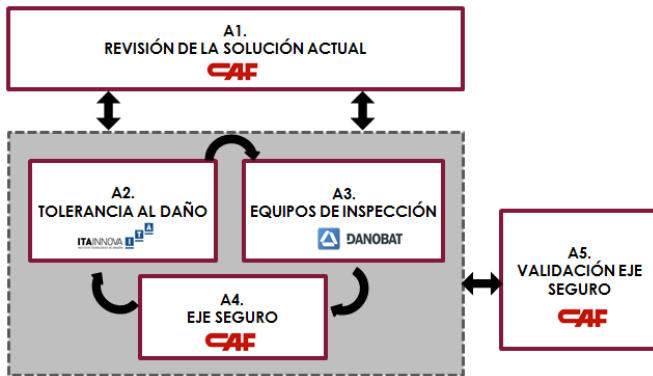
The development of technologies and methodologies for the design and monitoring of axles will favor the growth and internationalization of the Spanish railway industry by providing components and maintenance services of higher performance.

<p style="text-align: center;">DATOS</p> <p><u>Call</u>: RETOS-COLABORACIÓN 2016</p> <p>Ministerio de Economía y Competitividad (RTC-2016-4813-4)</p> <p><u>Duration</u>: 2016-2018</p> <p><u>Total budget</u>: 1.666.498,89 €</p>	 <pre> graph TD A1[A1. REVISIÓN DE LA SOLUCIÓN ACTUAL CAF] <--> A2[A2. TOLERANCIA AL DAÑO ITAINNOVA] A1 <--> A3[A3. EQUIPOS DE INSPECCIÓN DANOBAT] A2 --> A4[A4. EJE SEGURO CAF] A3 --> A4 A4 --> A5[A5. VALIDACIÓN EJE SEGURO CAF] style A2 stroke-dasharray: 5 5 style A3 stroke-dasharray: 5 5 style A4 stroke-dasharray: 5 5 style A5 stroke-dasharray: 5 5 </pre>	<p style="text-align: center;">CONSORTIUM</p> <p>CONSTRUCCIONES Y AUXILIAR DE FERROCARRILES, S.A.</p> <p>DANOBAT S. COOP.</p> <p>IDEKO, S. COOP.</p> <p>INSTITUTO TECNOLÓGICO DE ARAGÓN</p> 
--	--	--

BEA. Intelligent Monitoring System for Predictive Maintenance of Bogies based on Acoustic Emission

DESCRIPTION

The general objective of the project is to develop technologies that allow the detection, location and diagnosis, in incipient states of cracks of critical elements of the bogie, such as the axes, as well as the evolution of these cracks, being possible the prediction of the fracture of the component once the presence of a crack is detected.

RESULTS

The proposed technology can be installed in both existing and new bogies. It is estimated that in a first phase the product will receive a better reception to be installed in the bogies that are already in circulation since the probability of failures is greater than in the new bogies newly exited of the factory. At long term operators will require manufacturers to incorporate the new product in the bogies as standard.

KEY FIGURES

Call: Retos-Colaboración 2016. Ministerio de Economía Industria y Competitividad

(RTC-2016-5410-4)

Duration: 2016 - 2019

Total Budget: 846.467€



CONSORTIUM

Ferrocarrils de la Generalitat de Catalunya
 World Sensing Draco systems
 Fundació CTM Centre Tecnològic
 Universitat Politècnica de Catalunya



CARE. Personal protective equipment (PPE) for the control of electric risk

DESCRIPTION

The main objective of the project is to develop new personal protective equipment (PPE) based on the detection of the electric field of catenaries, transformers or other electrical installations. This PPE will provide the operator with a higher level of protection against electrical hazards, as well as provide information on possible falls suffered by the user, whether due to an electrical accident or during the normal course of his/her activity, and information on the person's state of health at the time of the accident, allowing the necessary emergency action without the need of interaction with the user. To do this, the following phases are established: I. Definition of requirements for the development of PPE that minimize electrical risk. II. Design and development of PPE (I-CARE). III. Design and implementation of management software. IV. Implementation of the system and monitoring of results.

RESULTS

Develop a new personal protective equipment (PPE) based on the detection of the electric field, with a much higher level of protection against electric risks. Advanced individual protection equipment, allowing the action of the emergency services without interaction with the user.

KEY FIGURES

Call: 2016

Duration: 2016-2019

Total budget: 532.210,85 euros

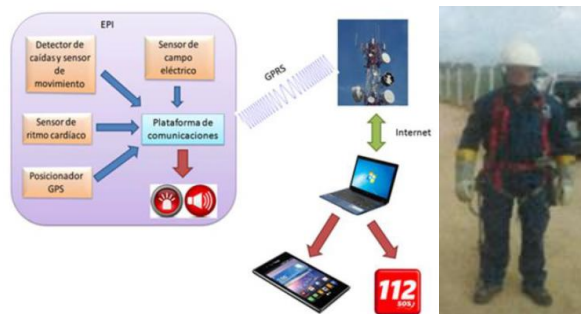

CONSORTIUM

COMSA, S.A.U.

LEITAT

COMSA
 CORPORACIÓN

LEITAT
 managing your technologies

CIFIL. Development of a system for the Characterization of Railway Infrastructures using Lidar Image.

DESCRIPTION

New system for recognition and inspection of railway infrastructures based on Laser Imaging Detection and Ranging (LIDAR technology) by developing new equipments and systems, adapting data processing algorithms and software, leading to a system that improves significantly the State of the Art.

RESULTS

This solution is directly related to the quality assurance of the railway infrastructures, which proposes a new and improved way of carrying out the overhaul of overhead power lines, specifically through the development of a more precise, more agile and more efficient system of measurement and revision of the electrical infrastructures. It is also cheaper than current products in the market and therefore, it is a product with great future, and a high capacity of penetration in the market.

KEY FIGURES

Call: Retos-Colaboración 2016. Ministerio de Economía y Competitividad (RTC-2016-5166-4)

Duration: 2016-2019

Total budget: 1.084.526 €

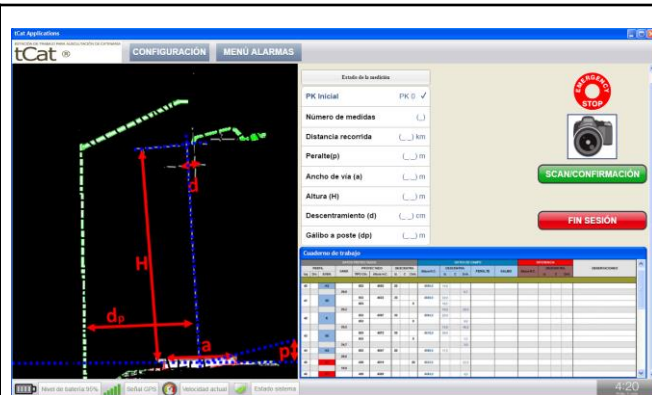

CONSORTIUM

TELÉFONOS LÍNEAS Y CENTRALES, S.A.

UNIVERSITAT POLITECNICA DE CATALUNYA

UNIVERSIDAD DE LEON

telice
TECHNOLOGY IN THE FIELD



HERMES. Tool for management and decision making aid in rail system maintenance

DESCRIPTION

The HERMES project is proposed as a new information system and management of the railway maintenance that implies a leap forward in the following areas:

- Modularity and scalability: HERMES will have some modules that can be used separately or integrated in a single solution based on Cloud Computing.
- Risk management: In order to establish a vehicle and infrastructure maintenance policy, the decisions risk must be known.
- Economic optimization of the maintenance process through maintenance logistics modelling and the assessment of their costs.
- Control and monitoring of maintenance tasks through a ticketing system of maintenance and incidents.

RESULTS

The developed platform will allow the implantation of a predictive maintenance strategy that will ensure the optimization of means and times, the reduction of the maintenance costs and a better control of the operation risks.

KEY FIGURES

Call: Retos-Colaboración 2016. Ministerio de Economía Industria y Competitividad

(RTC-2016-5204-4)

Duration: 2016 - 2019

Total budget: 945.918,59€

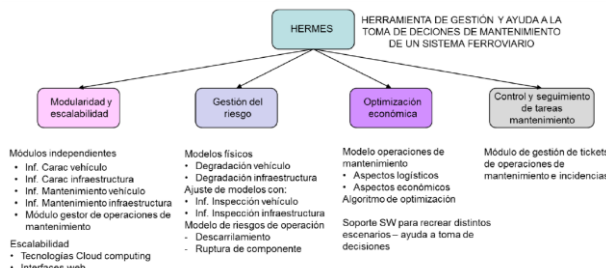

CONSORTIUM

Ferrocarrils de la Generalitat de Catalunya
Vias y Construcciones INYCOM CEIT



PYRKAST. Premium brake discs for high-speed trains

DESCRIPTION

The objective of this project is to develop a new generation of premium brake discs for high speed trains. These brake discs are characterized by presenting greater braking capacity and longer service life, being safer and more reliable than conventional ones, looking for zero defect.

RESULTS

Thanks to this product development, the reliability of the high speed brake systems will be increased. This is a critical issue in this type of transport which is growing exponentially.

KEY FIGURES

Call: Retos-Colaboración 2016.

Ministry of Economy and Competitiveness.

(RTC-2016-4880-4)

Duration: 2016-2018

Total budget: 1.176.508,00 €

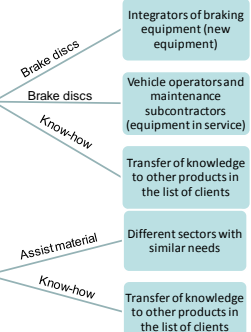

- Integrators of braking equipment (new equipment)
- Vehicle operators and maintenance subcontractors (equipment in service)
- Transfer of knowledge to other products in the list of clients
- Different sectors with similar needs
- Transfer of knowledge to other products in the list of clients

CONSORTIUM

Piezas y Rodajes S.A.
ASK Chemicals
Casa Maristas Azterlan
Universidad del País Vasco



SENSE ROD. Monitorization and diagnosis solutions for the advanced management of main rolling stock components

DESCRIPTION

Development of technologies for data acquisition, and monitorization and diagnosis solutions, that will enable an optimization of Rolling Stock management lowering vehicle's LCC and improving train availability.

RESULTS

The development of technologies and advanced diagnosis methodologies will enhance the competitiveness of Spanish railway industry in international tenders, through vehicles and services of higher performance.

KEY FIGURES

Call: RETOS-COLABORACIÓN 2016

Ministerio de Economía y Competitividad
 (RTC-2016-4634-4)

Duration: 2016-2017

Total budget: 936.570,79€



CONSORTIUM

CONSTRUCCIONES Y AUXILIAR DE FERROCARRILES, S.A.

CENTRO DE ENSAYOS y ANALISIS CETEST, S.L.

IKERLAN, S. COOP.



SIGNAL – Incident Intelligent Management System for Commuter Trains

DESCRIPTION: Incidents and emergency events in passenger rail transport are more frequent than expected. One of the top priorities is to minimize the consequences of this type of events by ensuring the safety of the passengers. This responsibility often falls on people who must make decisions quickly and efficiently. To achieve this goal there are predefined plans that establish an orderly sequence of actions where it has been proven to be ineffective and insufficient. The objective of SIGNAL is to develop and test an intelligent management system prototype capable of supporting decision makers and managers in front of incidents and emergencies in commuter trains.

RESULTS: SIGNAL will be able to offer decisions and actions suggestions in real time, mainly oriented to guarantee the safety and support for passengers, based on the analysis of multiple alternatives with advanced computational modeling and simulation techniques and the use of artificial intelligence methods , expert systems and decision trees. This will allow the decision-maker to take scientific-based measures, reduce decision cycles, and thus increase effectiveness in resolving the event.

KEY FIGURES

Call: Retos-Colaboración 2016.
 Ministerio de Economía, Industria y Competitividad (RTC-2016-5474-4)

Duration: 2016 – 2019

Total budget: 399.384,27 €

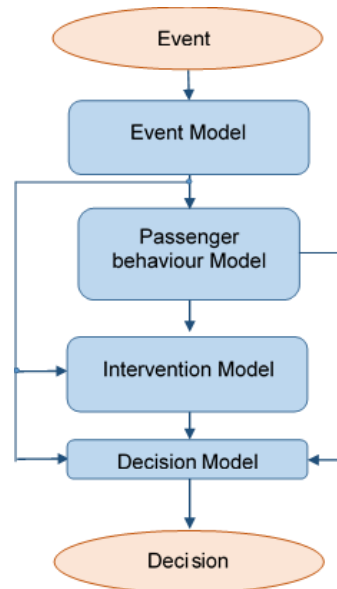

CONSORTIUM



Universidad de Cantabria
 (GIDAI)

SINATU. Inertial auscultation system of concrete tunnel linings

DESCRIPTION

The general objective of the SINATU project is to design a new inertial auscultation system to install in a tunnel which will be capable to characterize the structural state of the concrete that forms part of the coating while the vehicle passes through it.

RESULTS

Design of inertial sensors network to place on the concrete lining of the tunnel which will be able to record the vibratory behavior of the tunnel. Send this information automatically and instantaneously to the control center. And furthermore, to have a management software able to process and analyze the sensors data and to obtain as a result the structural state of the concrete lining of the tunnel detecting, classifying and locating the defects in it.

KEY FIGURES

Convocatoria: Retos-Colaboración 2016.

Ministerio de Economía Industria y Competitividad (RTC-2016-5038-4)

Duración: 2016 - 2019

Presupuesto Total: 1.078.988€

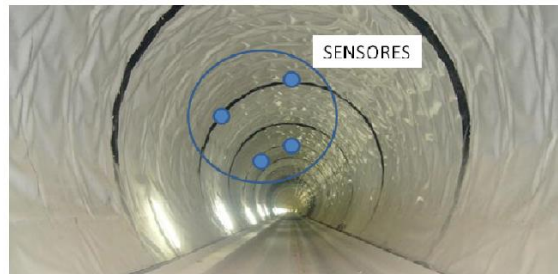

CONSORTIUM

Ferrocarrils de la Generalitat de Catalunya
 Comsa corporación
 Universitat Politècnica de València



UNIVERSITAT
 POLITÈCNICA
 DE VALÈNCIA



FGC
Ferrocarrils
 de la Generalitat
 de Catalunya



COMSA
 CORPORACIÓN

Spanish Railways Technological Platform – PTFE

Technical Secretariat
Fundación de los Ferrocarriles Españoles
www.ptferroviaria.es

For further information please contact: eprieto@ffe.es / aherranz@ffe.es